

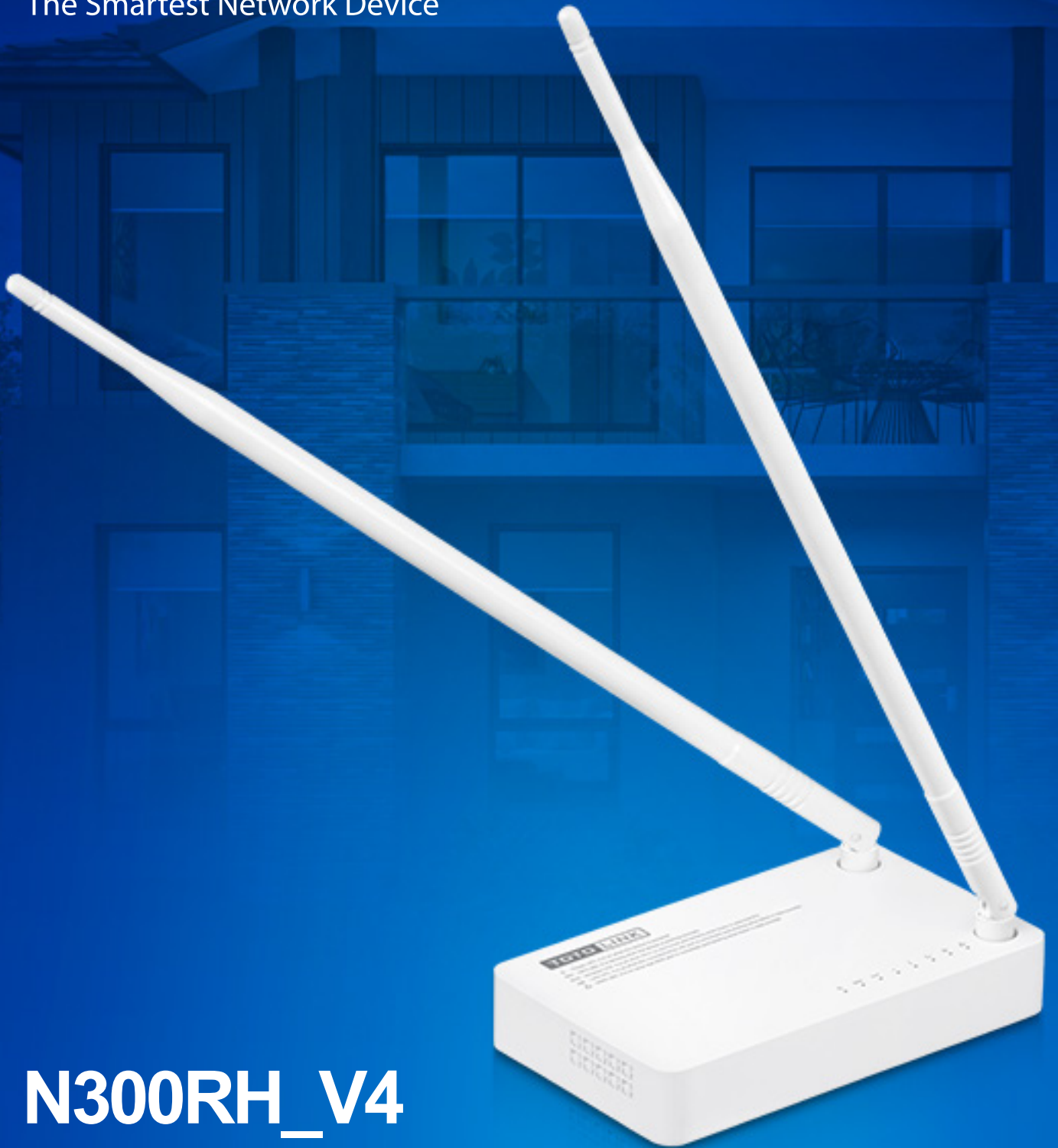

www.totolink.net

The Smartest Network Device



N300RH_V4

300Mbps

Long Range Wireless N Router



Long Range



Wi-Fi Schedule



Quality of Service

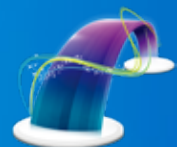

Universal Repeater

➤ Overview

300Mbps Long Range Wireless N Router

Model No. **N300RH_V4**

N300RH_V4 is a Long Range Wireless Router designed to provide excellent Wi-Fi experience over long distance. It complies with 802.11n standard and delivers wireless transmission speed up to 300Mbps. Two detachable high performance antennas significantly enhance the signal stability and offer extensive Wi-Fi range with less dead spot. So it is the most popular and practical for medium-sized home and small office use.



➤ Features

- Complies with IEEE 802.11n/g/b standards for 2.4GHz Wireless LAN.
- Up to 300Mbps data rate for Wi-Fi network.
- Advanced MIMO technology enhances the throughput and wireless coverage.
- Supports DHCP, Static IP, PPPoE, PPTP, L2TP broadband functions.
- Provides 64/128-bit WEP, WPA, WPA2 and WPA/WPA2 (TKIP+AES) security.
- Connects to secure network easily and fast using WPS.
- Supports IP, Port, MAC, URL filtering and Port Forwarding.
- QoS: Bandwidth Control based on IP/MAC.
- Multi-SSID allows user to create multiple SSIDs according to their needs.
- Supports VLAN function for IPTV and other internet services.
- Universal repeater and WDS function for easy Wi-Fi extension.
- High output power expands the wireless coverage and improve connection stability.



Selling point

300Mbps Wireless N Speed

Complying with the 802.11n standard, N300RH_V4 delivers Wi-Fi speed up to 300Mbps, satisfying all internet activities like network communication, online gaming and video streaming.

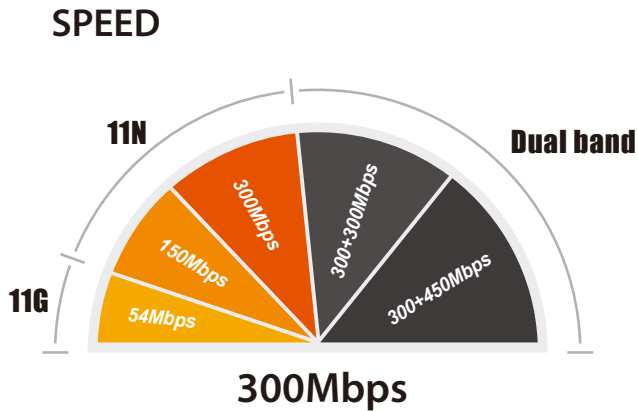

RANGE

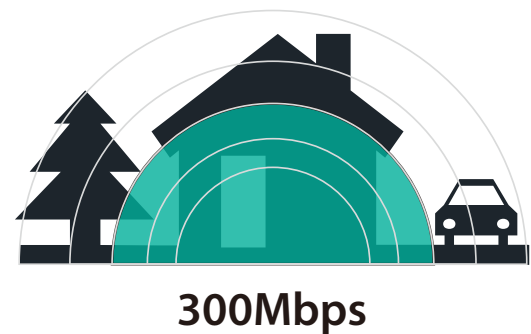

Extensive Wireless Coverage

Two 11dBi antennas and high output power design significantly enhances the signal stability and provides extensive Wi-Fi range with less dead spots.

Excellent Wi-Fi Connection over Long Distance

Stable and fast Wi-Fi connection over long distance makes your home network sharing more enjoyable in every corner.



Specification

Hardware

Processor	- Qualcomm Atheros 560MHz CPU
Memory	- 128MB DDR2 RAM, 16MB Flash
Interface	- 4*10/100Mbps LAN Ports - 1*10/100Mbps WAN Port
Power Supply	- 12VDC/1A
Antenna	- 2*11dBi detachable antennas
Passive PoE	- WAN Port & the LAN Port beside the WAN Port Supported
Button	- 1 *RST Button - 1 *WPS Button
LED Indicators	- 1*Power, 1*CPU, 1*Wireless, 1*WAN, 4*LAN
Dimensions (L x W x H)	- 175 x 102 x 29 mm (not including antennas)

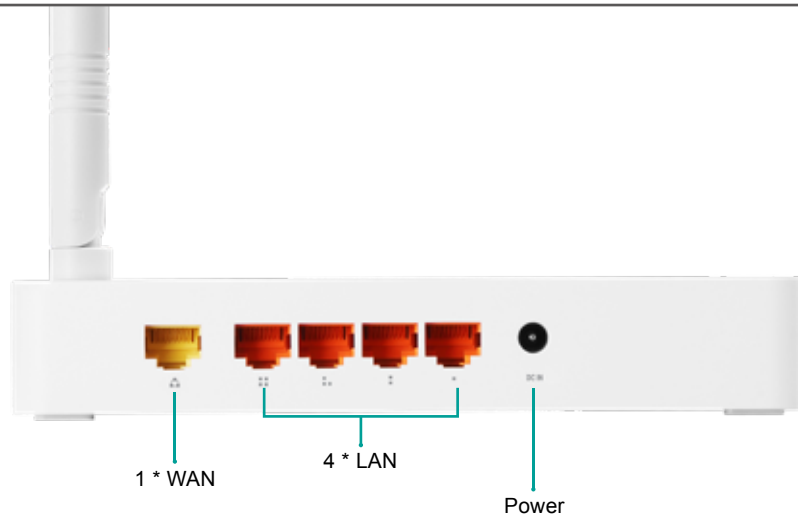

Wireless

Standards	- IEEE 802.11n, - IEEE 802.11g, - IEEE 802.11b
RF Frequency	- 2.4~2.4835GHz
Data Rate	- 802.11n: Up to 300Mbps - 802.11g: Up to 54Mbps (dynamic) - 802.11b: Up to 11Mbps (dynamic)
EIRP	- < 20dBm (For countries using CE standard) - < 27dBm (For countries using FCC standard)
Wireless Security	- 64/128-bit WEP, WPA/WPA2, WPA-PSK/WPA2-PSK (TKIP/AES)
Reception Sensitivity	- 270M: -61 dBm@10% PER - 135M: -65 dBm@10% PER - 54M: -68 dBm@10% PER - 11M: -85 dBm@8% PER - 6M: -88 dBm@10% PER - 1M: -90 dBm@8% PER

Specification

Software

Operation Mode	<ul style="list-style-type: none">- Gateway Mode- Bridge Mode- Repeater Mode- WISP Mode
Network	<ul style="list-style-type: none">- Static DHCP Setting, IPTV
WAN Type	<ul style="list-style-type: none">- DHCP/Static IP/PPPoE/PPTP /L2TP
Wireless Functions	<ul style="list-style-type: none">- Multiple SSID, MAC Authentication, WDS, WPS, WMM
Schedule	<ul style="list-style-type: none">- Reboot Schedule, Wireless Schedule
QoS	<ul style="list-style-type: none">- QoS Setup, Connect Limit Control
Firewall	<ul style="list-style-type: none">- MAC Filtering, IP Filtering, Port Filtering, URL Filtering Port Forwarding, DMZ
Management	<ul style="list-style-type: none">- Administrator Setting, Time Setting, DDNS, Remote Management, UPnP, Upgrade Firmware, System Configuration, System Log, and more

Others

Package Contents	<ul style="list-style-type: none">- N300RH_V4 Wireless Router *1- Detachable antenna*2- Power Adapter *1- Ethernet Cable *1- Quick Installation Guide *1
Environment	<ul style="list-style-type: none">- Operating Temperature: 0℃~40℃ (32℉~104℉)- Storage Temperature: -40℃~70℃ (-40℉~158℉)- Operating Humidity: 10%~90% non-condensing- Storage Humidity: 5%~90% non-condensing

ZIONCOM (HK) TECHNOLOGY LIMITED

Copyright©ZIONCOM (HK) TECHNOLOGY CO., LTD. All Rights Reserved.

Headquarter & R&D Center

7/F, Unit D, 4 Building Shenzhen Software Industry Base, Xuefu Road, Nanshan District, Shenzhen, Guangdong, China

Tel : +86-755-6136-3288 (Ext.867) | FAX : +86-755-6136-3344

Factory

Building A1 & A2 Lantian Technology Park, Xinyu Road, Xinqiao Henggang Block, Shajing Street, Baoan District, Shenzhen, Guangdong, China

Direct Line : +86-755-3686-1188(Ext. 5810) | FAX : +86-755-3686-1133

N300RH_V4

300Mbps Long Range Wireless N Router