

Quick Installation Guide

Wireless Dual Band Router

Suitable for: A800R

V1.1706

Copyrights by TOTOLINK. All rights reserved. Website: <http://www.totolink.net>
Information in this document is subject to change without prior notice.

1 Hardware Installation

Default SSID
2.4G: TOTOLINK_A800R
5G: TOTOLINK_A800R_5G

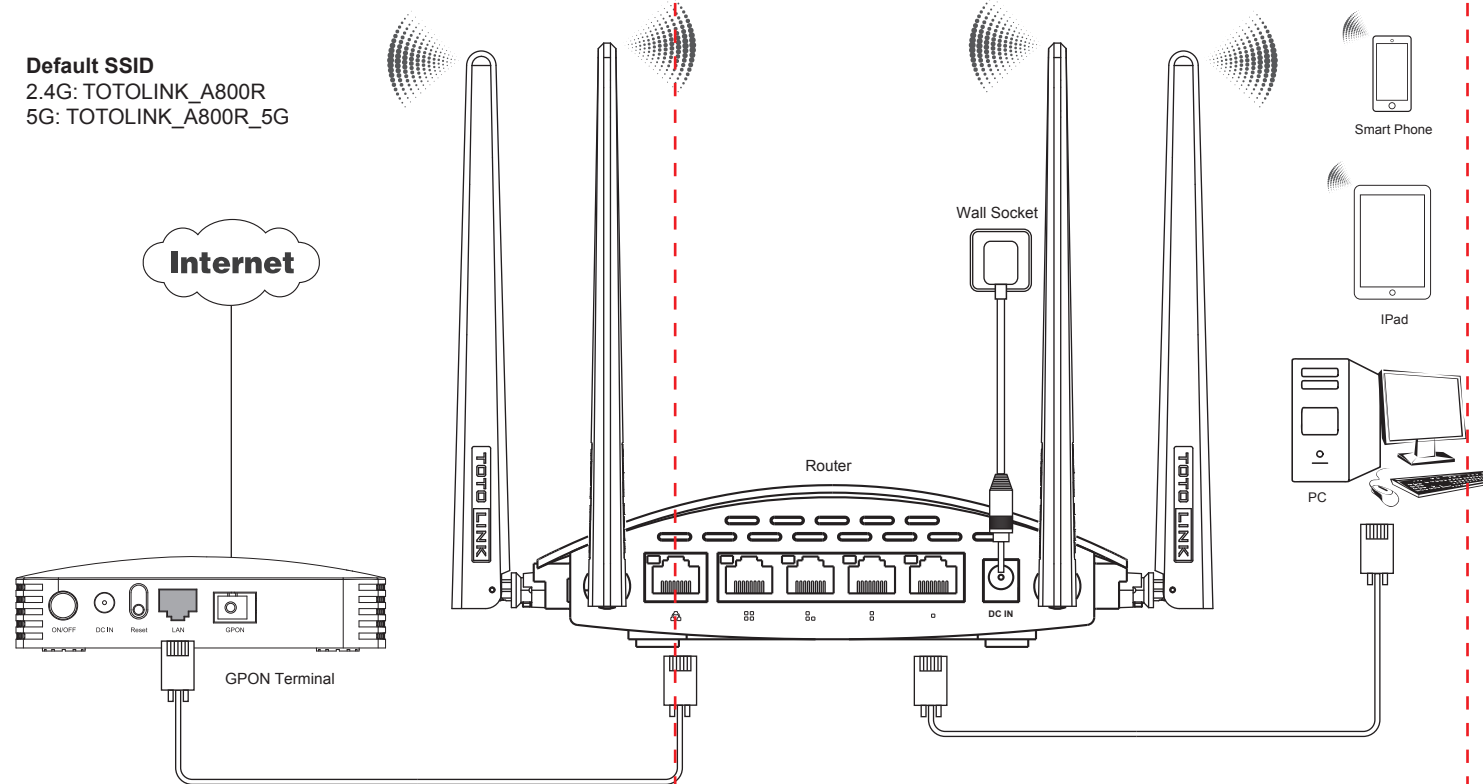

LED Indicators

Status	Indicator	Description
On	Slow blinking	The router is starting or WPS enabled
On	Fast blinking	The router is working normally
On	Press RST/WPS button for 5 seconds, the Status LED light blinks fast	
Off	Off	Power is off
WAN	On	The WAN port is connected
WAN	Off	The WAN port is not connected
LAN	On	There is device connected to LAN port 1/2/3/4.
LAN	Off	No device connected to LAN port 1/2/3/4.

Ports and Buttons Description

DC IN	Connect with the power adapter
WAN	Connect to ADSL modem or Internet Cable
LAN	Connect to PC or Laptop
RST/WPS	Press for 1s, WPS enabled; press for more than 5s, Reset function enabled.

NOTE:

1. Please disconnect the power adapter and all cables during thunderstorm weather;
2. Keep away from heat source and keep well ventilated;
3. Please pay attention to the waterproofing and moisture-proof when storing, transporting and running.
4. Please use the power adapter provided with the router.

2 Configure the Router

- 1 Run any Web browser. Enter **192.168.0.1** in the address bar.

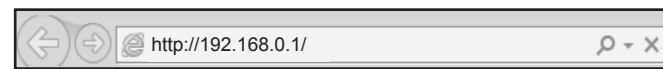

- 2 Enter **admin** for both **User Name** and **Password**, then click **LOGIN**.

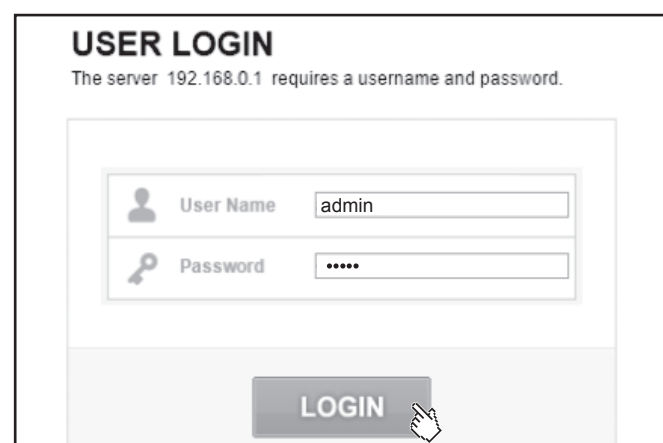

- 3 Now you can see the **Easy Setup** page. All basic settings could be done here, including **Internet Settings** and **5GHz & 2.4GHz Wireless Settings**.

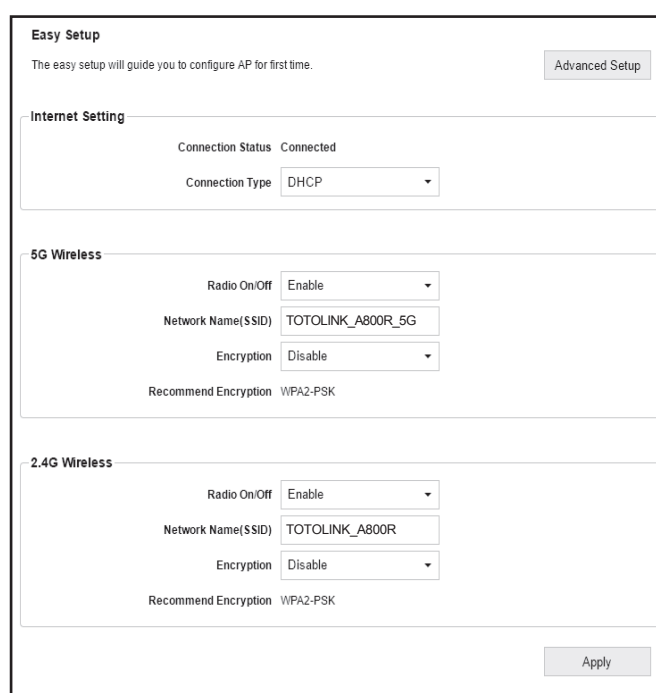

- 4 **Internet Settings**. **Connection Status** shows physical connection of router's WAN port. Choose one **Connection Type** according to your ISP (Internet Service Provider).

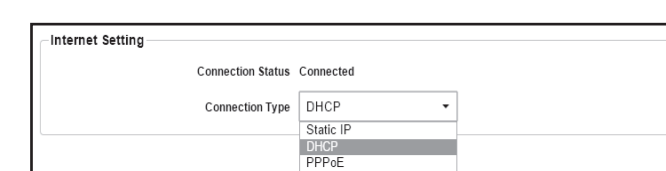

NO.	Connection Type	Description
A	DHCP	No configuration, simply connect the WAN port to existing Ethernet port by cable.
B	Static IP	You're required to enter IP Address, Subnet Mask, Default Gateway and DNS information provided by your ISP.
C	PPPoE	You're required to enter User Name and Password provided by your ISP.

- A **DHCP**. After choose **DHCP**, you can go on with the **5GHz & 2.4GHz Wireless Settings**.



- B. **Static IP**. If you choose **Static IP**, please enter **IP Address**, **Subnet Mask**, **Default Gateway** and **DNS** information provided by your ISP.

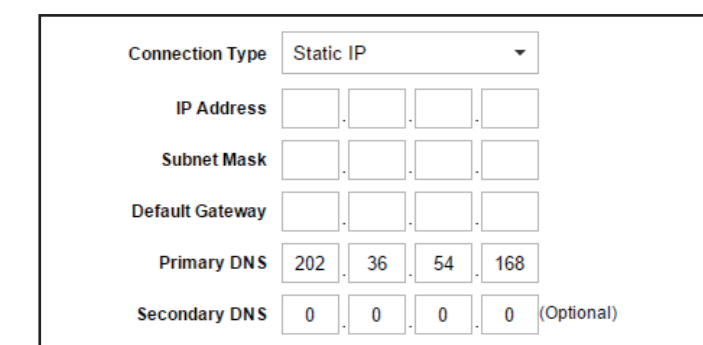

- C. **PPPoE**. If you choose **PPPoE**, please enter the **User Name** and **Password** provided by your ISP.



2 Configure the Router

- 5 **5G Wireless Settings**. You could customize your 5GHz wireless **Network Name (SSID)** and **Password**. The **WPA/WPA2-PSK** is recommended for **Encryption**.

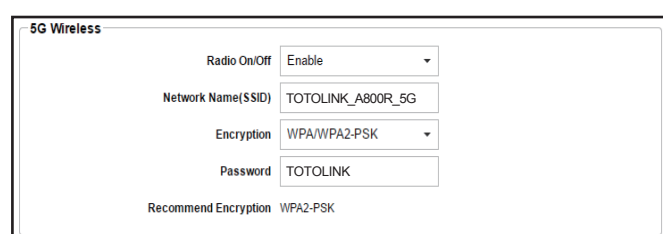

- 6 **2.4G Wireless Settings**. Verify or change your 2.4GHz wireless **Network Name (SSID)** and **Password**. The **WPA/WPA2-PSK** is recommended for **Encryption**. Click **Apply**.

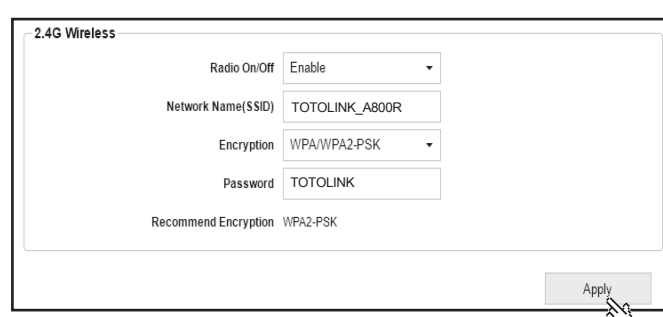

- 7 Connected successfully. Please click **Finish**.

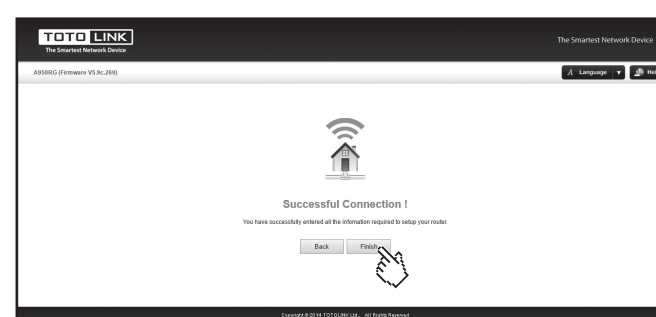

NOTE:
After you set the Key, please remember your SSID and the Key to connect with your wireless LAN.
WPS: press for about 1-3 seconds, the system LED indicator keep solid light, it means WPS working;
RST: press for about 5-8 seconds, the Status LED blinks quickly, the device will restore to factory default settings.

- 8 The router's **Status** interface turns up, showing all connection information.

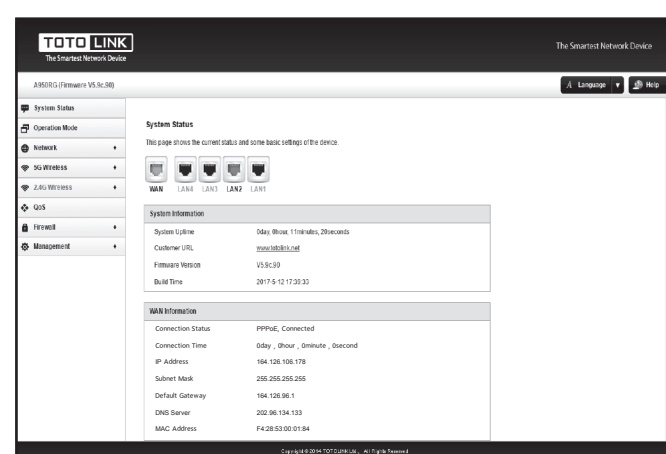

4 FAQ (Frequently Asked Questions)

- 1 What can I do if the login page does not appear?

1. Check your computer's IP address, make sure it is set to "Obtain an IP address automatically". Steps: right click **Network—Properties—Change adapter settings—Local Area Connection—Properties—Internet Protocol Version 4 (TCP/IPv4)**.
2. Make sure you enter the correct default access: **192.168.0.1**. Try again.
3. Use another web browser and try again.
4. Reboot your router and try again.

- 2 What can I do if I cannot access the Internet?

1. Check the Internet status by connecting a computer directly to the modem via Ethernet cable. If it is not working properly, contact your Internet Service Provider.
2. Setup your router again according to part 2 **Configure the Router**.
3. Reboot your cable modem (if have) and router, then try again.

- 3 How to reset the router to factory default Settings?

- Keep the router powered on, press the RST/WPS button on router about 10 seconds, it will restore to factory default settings.

- 4 What can I do if I forget the router's Web login User Name and Password?

- In case you changed your router's Login User Name and Password, we suggest you reset your router to factory default settings by above operations. Then use the following parameters to login the router's Web interface: **Default IP address: 192.168.0.1, User Name: admin, Password: admin**

3 Connect Wireless Network

After router settings, please follow below steps to connect wireless network:

- 1 Click or icon on the right bottom of your desktop:

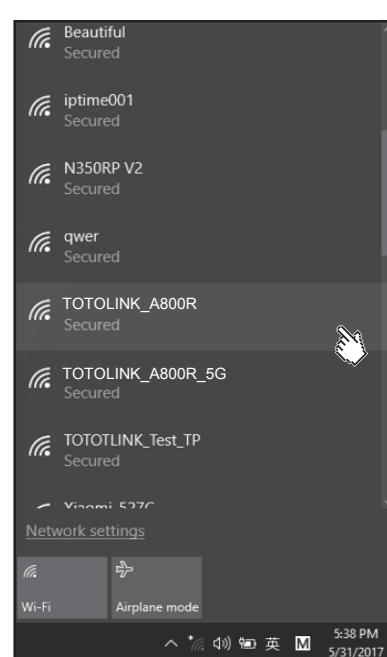

- 2 Choose the SSID that you have set on **Configure the Router**. Enter correct password. Click **Connect** or **Next**: 5G Wi-Fi is recommended if it is available for you.

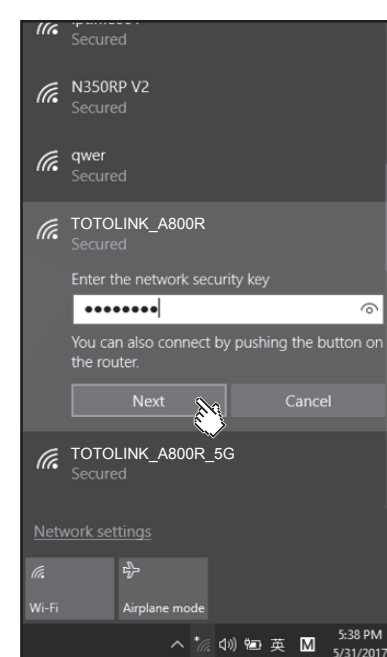

- 3 Wireless network connected. Enjoy your Wi-Fi.

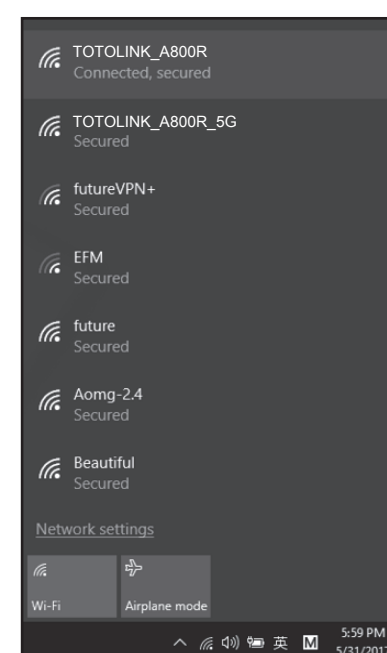

For Mobile device users, please go to **Settings—Wi-Fi** to connect wireless network.